

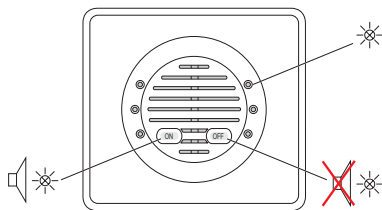

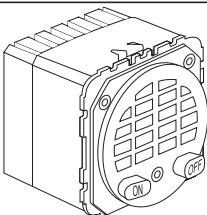





- Carillon à mélodies
- Gong met melodieën
- Musical door bell
- Melodie-gong
- Timbre con melodias



Ref.	AC	Fq	DC							IP IK	
675 41	230V	50 Hz	/	2	13	0 → 80 dB(A)	2A C	40mm	2x 1.5mm ²	IP 40 IK 04	- 10°C + 50°C
675 42	8-12V	50/60 Hz									

675 41

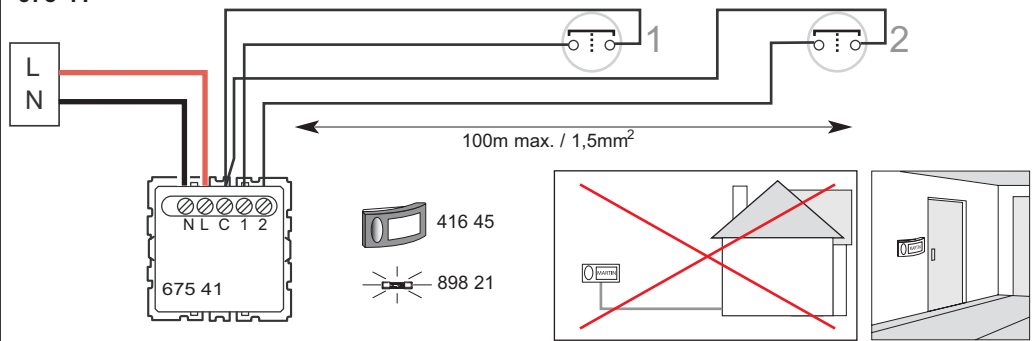

675 42

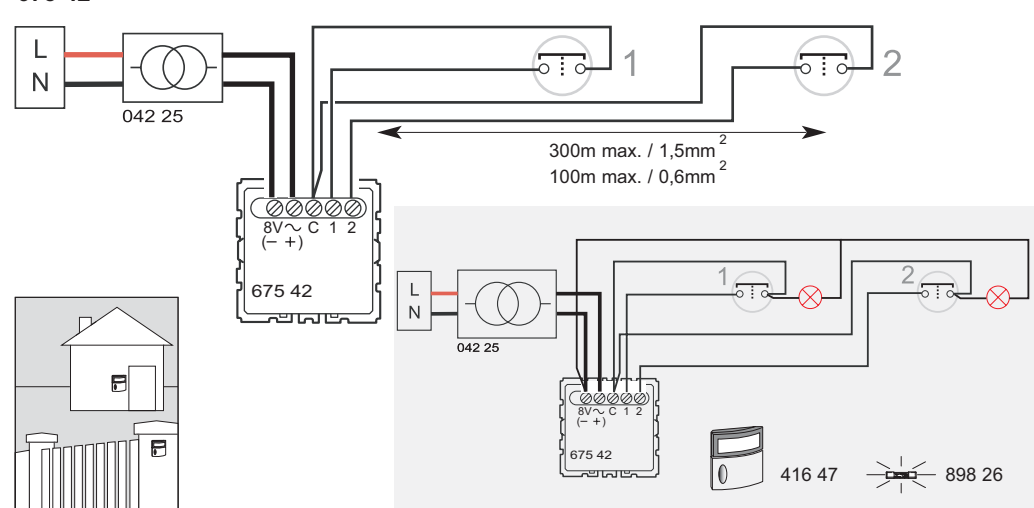

• Installation

• Installatie

• Installation

• Installation

• Instalación

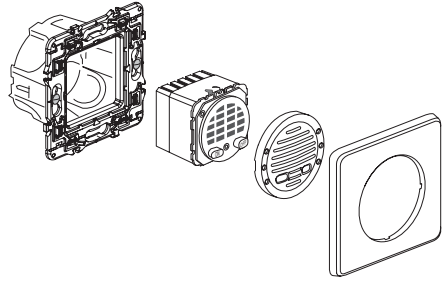
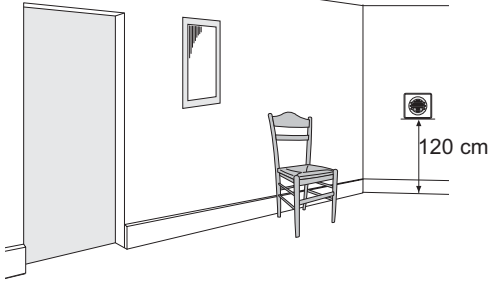

• Programmation
• Programmatie

• Programming
• Programacion

• Programmierung

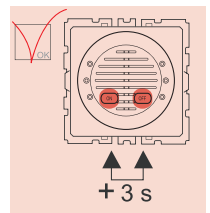
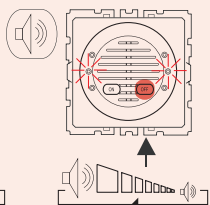
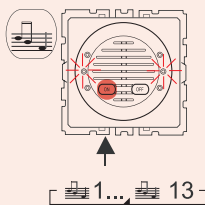
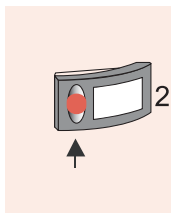
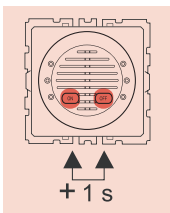
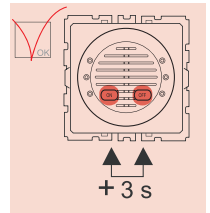
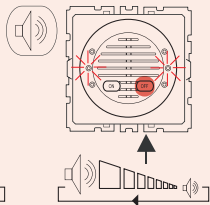
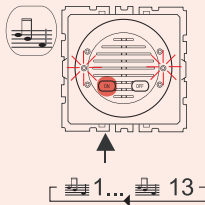
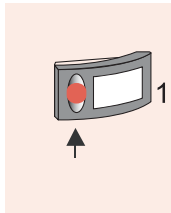
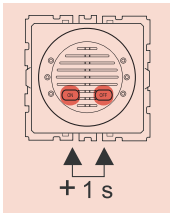
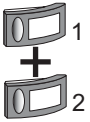
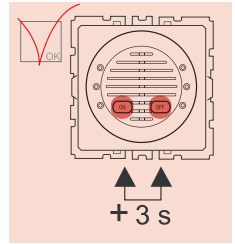
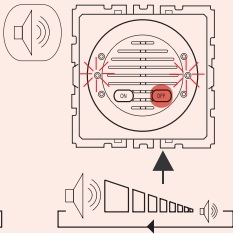
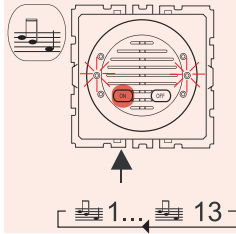
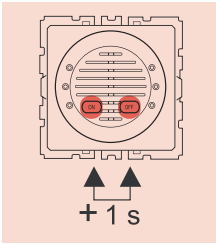

675 41

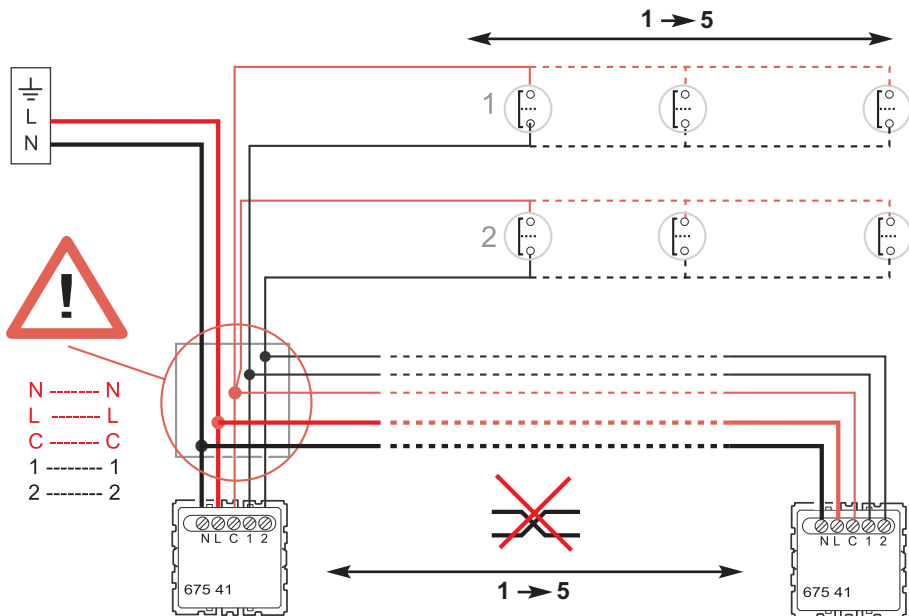

675 42

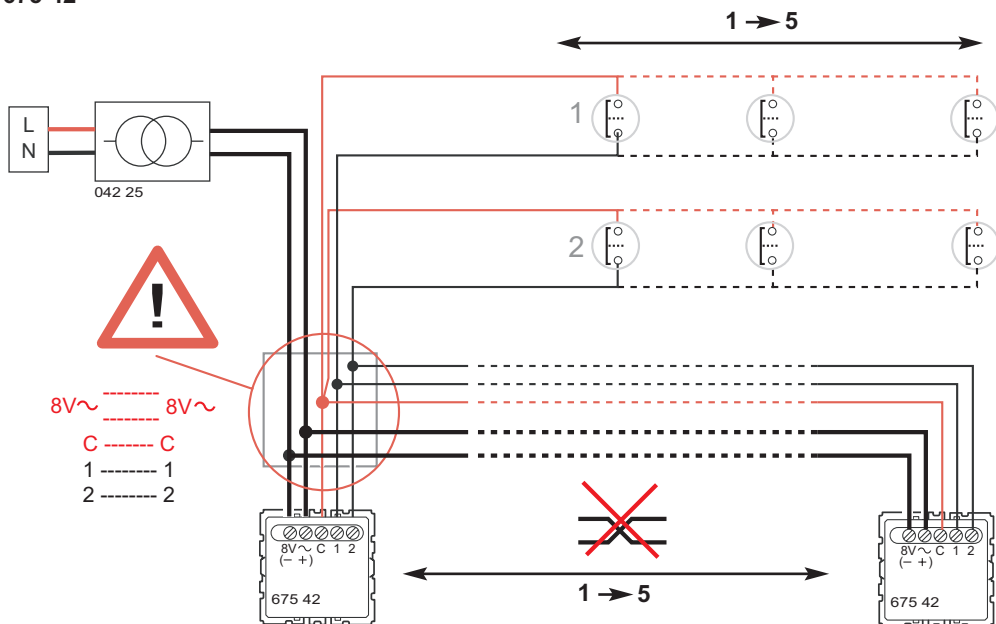

Consignes de sécurité

FR LU BE

Ce produit doit être installé de préférence par un électricien qualifié. Une installation et une utilisation incorrectes peuvent entraîner des risques de choc électrique ou d'incendie.

Avant d'effectuer l'installation, lire la notice, tenir compte du lieu de montage spécifique au produit.

Ne pas ouvrir l'appareil. Tous les produits Legrand doivent exclusivement être ouverts et réparés par du personnel formé et habilité par LEGRAND. Toute ouverture ou réparation non autorisée annule l'intégralité des responsabilités, droits à remplacement et garanties.

Utiliser exclusivement les accessoires d'origine.

Veiligheidsvoorschriften

NL BE

Dit product moet bij voorkeur door een vakbekwame elektricien geïnstalleerd worden. Bij een onjuiste installatie en een onjuist gebruik bestaat het risico van elektrische schokken of brand.

Lees alvorens de installatie uit te voeren de handleiding door en houd rekening met de specifieke montageplaats van het product.

Het apparaat niet openen. Alle Legrand producten mogen uitsluitend geopend en gerepareerd worden door personeel dat door Legrand is opgeleid en bevoegd verklaard. In geval van ongeoorloofd openen of repareren kan geen enkele aansprakelijkheid aanvaard worden, vervalt het recht op vervanging en zijn de garanties niet meer geldig.

Gebruik uitsluitend originele accessoires.

Safety instructions

GB IE

This product should be installed preferably by a qualified electrician. Incorrect installation and use can entail risk of electric shock or fire.

Before carrying out the installation, read the instructions and take account of the product's specific mounting location.

Do not open up the device. All Legrand products must be exclusively opened and repaired by personnel trained and approved by LEGRAND. Any unauthorised opening or repair completely cancels all liabilities and the rights to replacement and guarantees.

Only use genuine accessories.

Medidas de seguridad

ES

Este producto debe ser instalado preferentemente por un instalador electricista cualificado. La instalación y utilización incorrectas pueden generar riesgos de descargas eléctricas o de incendio. Antes de efectuar la instalación, leer el manual y, tener en cuenta el lugar de montaje específico del producto.

No abrir el aparato. Todos los productos Legrand deben ser abiertos y reparados exclusivamente por personal formado y autorizado por Legrand. Cualquier apertura o reparación no autorizada anula la integridad de las responsabilidades, derechos de cambio y garantías. Utilizar exclusivamente accesorios originales.

Sicherheitshinweise

DE

Dieses Produkt darf nur durch eine Elektro-Fachkraft eingebaut werden. Bei falschem Einbau bzw. Umgang besteht das Risiko eines elektrischen Schlages oder Brandes.

Vor der Installation die Bedienungsanleitung lesen, den produktspezifischen Montageort beachten. Das Gerät nicht öffnen. Alle Produkte von Legrand dürfen ausschließlich von durch Legrand geschultem und anerkanntem Personal geöffnet und repariert werden. Durch unbefugte

Öffnung oder Reparatur erlöschen alle Haftungs-, Ersatz- und Gewährleistungsansprüche. Ausschliesslich Originalzubehör der Marke Legrand verwenden.